

Features

- Unique double disc design with overtravel provides redundant sealing for leak tight shutoff
- Visual indication of open and shut position (Suffix "VI" & "C")
- Proof of closure switch 1 amp & visual indicator (Suffix "C")
- Silicon free construction (Suffix "SF")
- For on-off control of fuel gas in commercial and industrial gas burners
- 1/8" NPT pipe taps with plugs for routine testing
- Optional flange adapters for ease of installation and service

Fluid

Fuel Gas

Construction

Valve Parts in Contact with Fluids	
Body	Aluminum
Seals and Disc	NBR
Core Tube	305 Stainless Steel
Core Guide	Acetal
Rider Ring	PTFE
Core and Plugnut	430F Stainless Steel
Springs	302 Stainless Steel
Shading Coil	Copper
Pipe Plug	Zinc-Plated Steel

Electrical

	Standard Coil and Class of Insulation	Watt Rating and Power Consumption				Ambient Temp. °F	Spare Coil Family	
		AC					General Purpose	
		DC Watts	Watts	VA Holding	VA Inrush		AC	DC
General Purpose	F	35.1	20	43	240	-40 to 125	099257	206410
	B	14.9	-	-	-	-40 to 77	-	062691
	H	35.1	-	-	-	-40 to 132	-	236825
	H	-	20	43	240	-40 to 140	222345	-
Watertight	F	-	20.1	48	240	-40 to 125	272610	-
	H	-	20.1	48	240	-40 to 140	272810	-

Standard Voltages: 24, 120, 240 volts AC, 60 Hz (or 110, 220 volts AC, 50 Hz) 12, 24 volts DC.
Optional High Ambient Temp: 140°F Class H coil with prefix HB (3/4" to 2" AC only),
 132°F Class H coil with prefix HB (2" to 3" DC Only)

Solenoid Enclosures

General Purpose: RedHat metal Type 1 General Purpose housing has a 7/8" diameter hole to accept standard conduit hubs or connectors. Add prefix JB to General Purpose catalog number for a Junction Box construction with two 7/8" diameter knock-outs. (i.e. JB8214 265)

Watertight: RedHat II molded epoxy Type 1, 2, 3, 3S, 4 and 4X combination. General Purpose and Watertight solenoid enclosures with 1/2" conduit hub as standard. Add prefix JKP to Watertight catalog number for a Watertight Junction Box. (i.e. JKP8214G266)

Valve Response Time

Opening Time: Less than 1 second

Closing Time: Less than 1 second

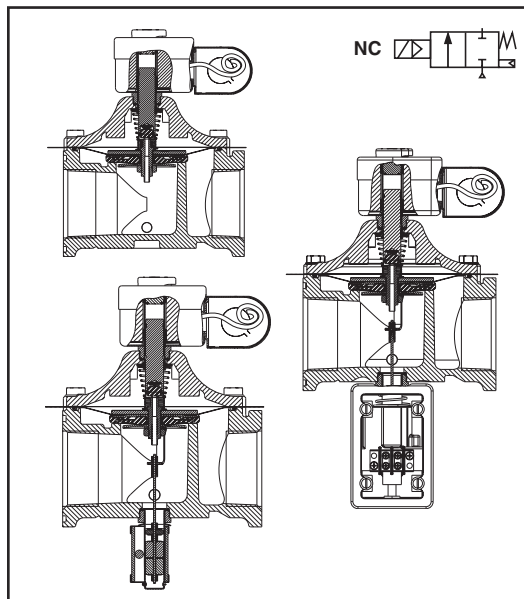

Approvals

UL listed to standard 429 "Electrically Operated Valves," Guide Y10Z, File MP618 Safety Shutoff Valves.

FM Approved to Class 7400 "liquid and gas safety shutoff valves."

CSA Certified to:

- 1) Standard C22.2 No. 139 "Electrically Operated Valves," File 010381.
- 2) Automatic Gas Valves Z21.21 (6.5), C/I, File 112872.
- 3) Automatic Gas Safety Shutoff Valves (3.9), File 112872.

COMBUSTION

Specifications - Standard (English units)

Pipe Size (in)	Orifice Size (in)	Cv Flow Factor	Flow Capacity ^① ft ³ /hr	Fuel Gas Capacity ^① Btu/hr	Operating Pressure Differential (psi)		Max. Fluid Temp. °F		Catalog Number	Const. Ref.		Agency			Watt Rating/ Class of Coil Insulation		Approx. Shipping Weight (lbs)
					Min.	Max.	AC	DC		AC	DC	UL	FM	CSA	AC	DC	
GENERAL PURPOSE																	
3/4	1 5/8	11	593	593,200	0	5	125	77	8214 235	1	○	-	○	20/F	14.9/B	5.1	
1	1 5/8	21	1132	1,132,300	0	5	125	77	8214 250	1	○	-	○	20/F	14.9/B	5.0	
1 1/4	1 5/8	32	1726	1,725,500	0	5	125	77	8214 260	1	○	-	○	20/F	14.9/B	4.9	
1 1/2	1 5/8	35	1887	1,887,200	0	5	125	77	8214 270	1	○	-	○	20/F	14.9/B	4.7	
1 1/4 (High Flow)	2 3/32	36	1925	1,925,000	0	5	125	77	8214 265	2	○	-	○	20/F	14.9/B	6.9	
1 1/2 (High Flow)	2 3/32	45	2406	2,406,000	0	5	125	77	8214 275	2	○	-	○	20/F	14.9/B	6.6	
2	2 3/32	55	2941	2,940,500	0	5	125	77	8214 280	2	○	-	○	20/F	14.9/B	6.2	
2 (High Flow)	3	75	4044	4,044,100	0	5	125	125	8214 285	3	16	○	-	○	20/H	35.1/F	13.1
2 1/2	3	104	5608	5,607,800	0	5	125	125	8214 290	3	16	○	-	○	20/H	35.1/F	12.6
3	3	105	5662	5,661,700	0	5	125	125	8214 240	3	16	○	-	○	20/H	35.1/F	11.7
WATERTIGHT																	
3/4	1 5/8	11	593	593,200	0	5	125	-	8214G236	4	-	○	-	○	20.1/F	-	5.1
1	1 5/8	21	1132	1,132,300	0	5	125	-	8214G251	4	-	○	-	○	20.1/F	-	5.0
1 1/4	1 5/8	32	1726	1,725,500	0	5	125	-	8214G261	4	-	○	-	○	20.1/F	-	4.9
1 1/2	1 5/8	35	1887	1,887,200	0	5	125	-	8214G271	4	-	○	-	○	20.1/F	-	4.7
1 1/4 (High Flow)	2 3/32	36	1925	1,925,000	0	5	125	-	8214G266	5	-	○	-	○	20.1/F	-	6.9
1 1/2 (High Flow)	2 3/32	45	2406	2,406,000	0	5	125	-	8214G276	5	-	○	-	○	20.1/F	-	6.6
2	2 3/32	55	2941	2,940,500	0	5	125	-	8214G281	5	-	○	-	○	20.1/F	-	6.2

○ = Safety Shutoff Valve. ① 1" W.C. Drop @ 2" W.C. Inlet Pressure, 1,000 Btu/cu.ft. or more, 0.64 Specific Gravity Gas.

Specifications - Standard (Metric units)

Pipe Size (in)	Orifice Size (mm)	Kv Flow Factor	Flow Capacity ^① (m ³ /hr)	Fuel Gas Capacity ^① Btu/hr	Operating Pressure Differential (bar)		Max. Fluid Temp. °C		Catalog Number	Const. Ref.		Agency			Watt Rating/ Class of Coil Insulation		Approx. Shipping Weight (kgs)
					Min.	Max.	AC	DC		AC	DC	UL	FM	CSA	AC	DC	
GENERAL PURPOSE																	
3/4	41	9.4	17	593,200	0	0.3	52	25	8214 235	1	○	-	○	20/F	14.9/B	2.3	
1	41	17.9	32	1,132,300	0	0.3	52	25	8214 250	1	○	-	○	20/F	14.9/B	2.3	
1 1/4	41	27.3	49	1,725,500	0	0.3	52	25	8214 260	1	○	-	○	20/F	14.9/B	2.2	
1 1/2	41	29.9	53	1,887,200	0	0.3	52	25	8214 270	1	○	-	○	20/F	14.9/B	2.1	
1 1/4 (High Flow)	53	30.7	55	1,925,000	0	0.3	52	25	8214 265	2	○	-	○	20/F	14.9/B	3.1	
1 1/2 (High Flow)	53	38.4	68	2,406,000	0	0.3	52	25	8214 275	2	○	-	○	20/F	14.9/B	2.9	
2	53	46.9	83	2,940,500	0	0.3	52	25	8214 280	2	○	-	○	20/F	14.9/B	2.8	
2 (High Flow)	76	64.0	115	4,044,100	0	0.3	52	52	8214 285	3	16	○	-	○	20/H	35.1/F	6.0
2 1/2	76	88.7	159	5,607,800	0	0.3	52	52	8214 290	3	16	○	-	○	20/H	35.1/F	5.7
3	76	89.6	160	5,661,700	0	0.3	52	52	8214 240	3	16	○	-	○	20/H	35.1/F	5.3
WATERTIGHT																	
3/4	41	9.4	17	593,200	0	0.3	52	-	8214G236	4	-	○	-	○	20.1/F	-	2.3
1	41	17.9	32	1,132,300	0	0.3	52	-	8214G251	4	-	○	-	○	20.1/F	-	2.3
1 1/4	41	27.3	49	1,725,500	0	0.3	52	-	8214G261	4	-	○	-	○	20.1/F	-	2.2
1 1/2	41	29.9	53	1,887,200	0	0.3	52	-	8214G271	4	-	○	-	○	20.1/F	-	2.1
1 1/4 (High Flow)	53	30.7	55	1,925,000	0	0.3	52	-	8214G266	5	-	○	-	○	20.1/F	-	3.1
1 1/2 (High Flow)	53	38.4	68	2,406,000	0	0.3	52	-	8214G276	5	-	○	-	○	20.1/F	-	2.9
2	53	46.9	83	2,940,500	0	0.3	52	-	8214G281	5	-	○	-	○	20.1/F	-	2.8

○ = Safety Shutoff Valve. ① 1" W.C. Drop @ 2" W.C. Inlet Pressure, 1,000 Btu/cu.ft. or more, 0.64 Specific Gravity

Specifications - Visual Indication (Suffix VI) (English units)

Pipe Size (in)	Orifice Size (in)	Cv Flow Factor	Flow Capacity ① (ft³/hr)	Fuel Gas Capacity ① (Btu/hr)	Operating Pressure Differential (psi)		Max. Fluid Temp. °F		Catalog Number	Const. Ref.	Agency			Watt Rating/Class of Coil Insulation		Approx. Shipping Weight (lbs)
					Min.	Max.	AC	DC			UL	FM	CSA	AC	DC	
GENERAL PURPOSE																
3/4	1 5/8	11	593	593,200	0	5	125	77	8214 235VI	6	○	○	○	20/F	-	5.3
1	1 5/8	21	1132	1,132,300	0	5	125	77	8214 250VI	6	○	○	○	20/F	-	5.2
1 1/4	1 5/8	32	1726	1,725,500	0	5	125	77	8214 260VI	6	○	○	○	20/F	-	5.1
1 1/2	1 5/8	35	1887	1,887,200	0	5	125	77	8214 270VI	6	○	○	○	20/F	-	4.9
1 1/4 (High Flow)	2 3/32	36	1925	1,925,000	0	5	125	77	8214 265VI	7	○	○	○	20/F	-	7.1
1 1/2 (High Flow)	2 3/32	45	2406	2,406,000	0	5	125	77	8214 275VI	7	○	○	○	20/F	-	6.8
2	2 3/32	55	2941	2,940,500	0	5	125	77	8214 280VI	7	○	○	○	20/F	-	6.4
2 (High Flow)	3	75	4044	4,044,100	0	5	125	-	8214 285VI	8	○	○	○	20/H	-	13.3
2 1/2	3	104	5608	5,607,800	0	5	125	-	8214 290VI	8	○	○	○	20/H	-	12.8
3	3	105	5662	5,661,700	0	5	125	-	8214 240VI	8	○	○	○	20/H	-	11.9
WATERTIGHT																
3/4	1 5/8	11	593	593,200	0	5	125	-	8214G236VI	9	○	○	○	20.1/F	-	5.3
1	1 5/8	21	1132	1,132,300	0	5	125	-	8214G251VI	9	○	○	○	20.1/F	-	5.2
1 1/4	1 5/8	32	1726	1,725,500	0	5	125	-	8214G261VI	9	○	○	○	20.1/F	-	5.1
1 1/2	1 5/8	35	1887	1,887,200	0	5	125	-	8214G271VI	9	○	○	○	20.1/F	-	4.9
1 1/4 (High Flow)	2 3/32	36	1925	1,925,000	0	5	125	-	8214G266VI	10	○	○	○	20.1/F	-	7.1
1 1/2 (High Flow)	2 3/32	45	2406	2,406,000	0	5	125	-	8214G276VI	10	○	○	○	20.1/F	-	6.8
2	2 3/32	55	2941	2,940,500	0	5	125	-	8214G281VI	10	○	○	○	20.1/F	-	6.4

○ = Safety Shutoff Valve. ① 1" W.C. Drop @ 2" W.C. Inlet Pressure, 1,000 Btu/cu.ft. or more, 0.64 Specific Gravity Gas.

Specifications - Visual Indication (Suffix VI) (Metric units)

Pipe Size (in)	Orifice Size (mm)	Kv Flow Factor	Flow Capacity ① (m³/hr)	Fuel Gas Capacity ① (Btu/hr)	Operating Pressure Differential (bar)		Max. Fluid Temp. °C		Catalog Number	Const. Ref.	Agency			Watt Rating/Class of Coil Insulation		Approx. Shipping Weight (kgs)
					Min.	Max.	AC	DC			UL	FM	CSA	AC	DC	
GENERAL PURPOSE																
3/4	41	9.4	17	593,200	0	0.3	52	25	8214 235VI	6	○	○	○	20/F	-	2.4
1	41	17.9	32	1,132,300	0	0.3	52	25	8214 250VI	6	○	○	○	20/F	-	2.4
1 1/4	41	27.3	49	1,725,500	0	0.3	52	25	8214 260VI	6	○	○	○	20/F	-	2.3
1 1/2	41	29.9	53	1,887,200	0	0.3	52	25	8214 270VI	6	○	○	○	20/F	-	2.2
1 1/4 (High Flow)	53	30.7	55	1,925,000	0	0.3	52	25	8214 265VI	7	○	○	○	20/F	-	3.2
1 1/2 (High Flow)	53	38.4	68	2,406,000	0	0.3	52	25	8214 275VI	7	○	○	○	20/F	-	3.0
2	53	46.9	83	2,940,500	0	0.3	52	25	8214 280VI	7	○	○	○	20/F	-	2.9
2 (High Flow)	76	64.0	115	4,044,100	0	0.3	52	-	8214 285VI	8	○	○	○	20/H	-	6.1
2 1/2	76	88.7	159	5,607,800	0	0.3	52	-	8214 290VI	8	○	○	○	20/H	-	5.8
3	76	89.6	160	5,661,700	0	0.3	52	-	8214 240VI	8	○	○	○	20/H	-	5.4
WATERTIGHT																
3/4	41	9.4	17	593,200	0	0.3	52	-	8214G236VI	9	○	○	○	20.1/F	-	2.4
1	41	17.9	32	1,132,300	0	0.3	52	-	8214G251VI	9	○	○	○	20.1/F	-	2.4
1 1/4	41	27.3	49	1,725,500	0	0.3	52	-	8214G261VI	9	○	○	○	20.1/F	-	2.3
1 1/2	41	29.9	53	1,887,200	0	0.3	52	-	8214G271VI	9	○	○	○	20.1/F	-	2.2
1 1/4 (High Flow)	53	30.7	55	1,925,000	0	0.3	52	-	8214G266VI	10	○	○	○	20.1/F	-	3.2
1 1/2 (High Flow)	53	38.4	68	2,406,000	0	0.3	52	-	8214G276VI	10	○	○	○	20.1/F	-	3.0
2	53	46.9	83	2,940,500	0	0.3	52	-	8214G281VI	10	○	○	○	20.1/F	-	2.9

○ = Safety Shutoff Valve. ① 1" W.C. Drop @ 2" W.C. Inlet Pressure, 1,000 Btu/cu.ft. or more, 0.64 Specific Gravity

Specifications - Proof of Closure (Suffix C) (English units)

Pipe Size (in)	Orifice Size (in)	Cv Flow Factor	Flow Capacity ① (ft³/hr)	Fuel Gas Capacity ① (Btu/hr)	Operating Pressure Differential (psi)		Max. Fluid Temp. °F		Catalog Number	Const. Ref.	Agency			Watt Rating/Class of Coil Insulation		Approx. Shipping Weight (lbs)
					Min.	Max.	AC	DC			UL	FM	CSA	AC	DC	
GENERAL PURPOSE																
3/4	1 5/8	11	593	593,200	0	5	125	77	8214 235C	11	○	○	○	20/F	-	5.6
1	1 5/8	21	1132	1,132,300	0	5	125	77	8214 250C	11	○	○	○	20/F	-	5.5
1 1/4	1 5/8	32	1726	1,725,500	0	5	125	77	8214 260C	11	○	○	○	20/F	-	5.4
1 1/2	1 5/8	35	1887	1,887,200	0	5	125	77	8214 270C	11	○	○	○	20/F	-	5.2
1 1/4 (High Flow)	2 3/32	36	1925	1,925,000	0	5	125	77	8214 265C	12	○	○	○	20/F	-	7.4
1 1/2 (High Flow)	2 3/32	45	2406	2,406,000	0	5	125	77	8214 275C	12	○	○	○	20/F	-	7.1
2	2 3/32	55	2941	2,940,500	0	5	125	77	8214 280C	12	○	○	○	20/F	-	6.7
2 (High Flow)	3	75	4044	4,044,100	0	5	125	-	8214 285C	13	○	○	○	20/H	-	13.6
2 1/2	3	104	5608	5,607,800	0	5	125	-	8214 290C	13	○	○	○	20/H	-	13.1
3	3	105	5662	5,661,700	0	5	125	-	8214 240C	13	○	○	○	20/H	-	12.2
WATERTIGHT																
3/4	1 5/8	11	593	593,200	0	5	125	-	8214G236C	14	○	○	○	20.1/F	-	5.6
1	1 5/8	21	1132	1,132,300	0	5	125	-	8214G251C	14	○	○	○	20.1/F	-	5.5
1 1/4	1 5/8	32	1726	1,725,500	0	5	125	-	8214G261C	14	○	○	○	20.1/F	-	5.4
1 1/2	1 5/8	35	1887	1,887,200	0	5	125	-	8214G271C	14	○	○	○	20.1/F	-	5.2
1 1/4 (High Flow)	2 3/32	36	1925	1,925,000	0	5	125	-	8214G266C	15	○	○	○	20.1/F	-	7.4
1 1/2 (High Flow)	2 3/32	45	2406	2,406,000	0	5	125	-	8214G276C	15	○	○	○	20.1/F	-	7.1
2	2 3/32	55	2941	2,940,500	0	5	125	-	8214G281C	15	○	○	○	20.1/F	-	6.7

○ = Safety Shutoff Valve. ① 1" W.C. Drop @ 2" W.C. Inlet Pressure, 1,000 Btu/cu.ft. or more, 0.64 Specific Gravity Gas.

Specifications - Proof of Closure (Suffix C) (Metric units)

Pipe Size (in)	Orifice Size (mm)	Kv Flow Factor	Flow Capacity ① (m³/hr)	Fuel Gas Capacity ① (Btu/hr)	Operating Pressure Differential (bar)		Max. Fluid Temp. °C		Catalog Number	Const. Ref.	Agency			Watt Rating/Class of Coil Insulation		Approx. Shipping Weight (kgs)
					Min.	Max.	AC	DC			UL	FM	CSA	AC	DC	
GENERAL PURPOSE																
3/4	41	9.4	17	593,200	0	0.3	52	25	8214 235C	11	○	○	○	20/F	-	2.5
1	41	17.9	32	1,132,300	0	0.3	52	25	8214 250C	11	○	○	○	20/F	-	2.5
1 1/4	41	27.3	49	1,725,500	0	0.3	52	25	8214 260C	11	○	○	○	20/F	-	2.4
1 1/2	41	29.9	53	1,887,200	0	0.3	52	25	8214 270C	11	○	○	○	20/F	-	2.3
1 1/4 (High Flow)	53	30.7	55	1,925,000	0	0.3	52	25	8214 265C	12	○	○	○	20/F	-	3.3
1 1/2 (High Flow)	53	38.4	68	2,406,000	0	0.3	52	25	8214 275C	12	○	○	○	20/F	-	3.1
2	53	46.9	83	2,940,500	0	0.3	52	25	8214 280C	12	○	○	○	20/F	-	3.0
2 (High Flow)	76	64.0	115	4,044,100	0	0.3	52	-	8214 285C	13	○	○	○	20/H	-	6.2
2 1/2	76	88.7	159	5,607,800	0	0.3	52	-	8214 290C	13	○	○	○	20/H	-	5.9
3	76	89.6	160	5,661,700	0	0.3	52	-	8214 240C	13	○	○	○	20/H	-	5.5
WATERTIGHT																
3/4	41	9.4	17	593,200	0	0.3	52	-	8214G236C	14	○	○	○	20.1/F	-	2.5
1	41	17.9	32	1,132,300	0	0.3	52	-	8214G251C	14	○	○	○	20.1/F	-	2.5
1 1/4	41	27.3	49	1,725,500	0	0.3	52	-	8214G261C	14	○	○	○	20.1/F	-	2.4
1 1/2	41	29.9	53	1,887,200	0	0.3	52	-	8214G271C	14	○	○	○	20.1/F	-	2.3
1 1/4 (High Flow)	53	30.7	55	1,925,000	0	0.3	52	-	8214G266C	15	○	○	○	20.1/F	-	3.3
1 1/2 (High Flow)	53	38.4	68	2,406,000	0	0.3	52	-	8214G276C	15	○	○	○	20.1/F	-	3.1
2	53	46.9	83	2,940,500	0	0.3	52	-	8214G281C	15	○	○	○	20.1/F	-	3.0

○ = Safety Shutoff Valve. ① 1" W.C. Drop @ 2" W.C. Inlet Pressure, 1,000 Btu/cu.ft. or more, 0.64 Specific Gravity

Dimensions inches (mm)

Const. Ref.		A	B	C	H	J	K	L	M	N	P	R	T	W
1	in	2.69	4.65	1.86	6.97	3.55	4.14	5.30	2.48	5.95	5.51	2.40	2.20	5.39
	mm	68	118	47	177	90	105	135	63	151	140	61	56	137
2	in	3.16	4.64	1.86	7.63	3.55	4.48	6.09	2.48	6.36	5.85	2.81	2.20	6.32
	mm	80	118	47	194	90	114	155	63	161	149	71	56	161
3	in	4.13	4.65	1.86	9.62	3.55	5.86	7.80	2.48	7.44	7.23	3.89	2.20	7.95
	mm	105	118	47	244	90	149	198	63	189	184	99	56	202
4	in	2.69	3.13	-	4.28	2.11	6.90	5.30	-	4.51	5.47	2.40	1.95	5.39
	mm	68	80	-	109	53	176	135	-	114	139	61	50	137
5	in	3.16	3.13	-	4.66	2.11	7.63	6.09	-	4.92	5.85	2.81	206.	6.32
	mm	80	80	-	118	53	194	155	-	125	149	71	52	161
16	in	4.13	5.49	1.86	10.3	4.13	5.71	7.8	3.31	8.03	7.91	3.89	3.31	6.32
	mm	105	147	47	261	105	145	198	84	204	201	99	84	161

Const. Ref. 1-3, 16

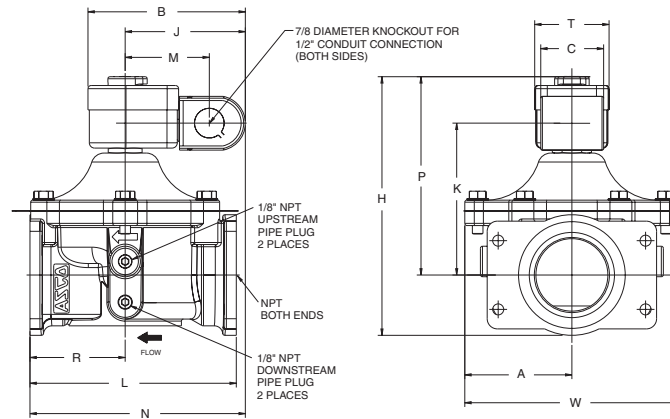

Const. Ref. 4, 5

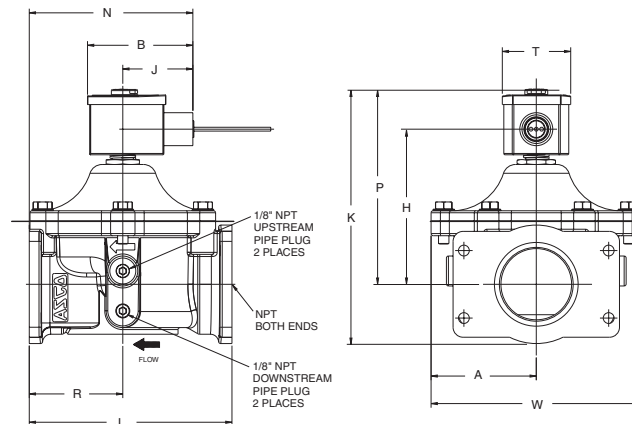

3/4" through 2" can be mounted with solenoid in any position above horizontal.
2" High Flow through 3" must be mounted with solenoid vertical and upright.

Dimensions inches (mm)

Const. Ref.		A	B	C	H	J	K	L	M	N	P	R	T	W
6	in	2.69	4.64	1.86	9.16	3.55	4.14	5.30	2.48	5.95	5.51	2.40	2.20	5.39
	mm	68	118	47	233	90	105	135	63	151	140	61	56	137
7	in	3.16	4.64	1.86	9.54	3.55	4.48	6.09	2.48	6.36	5.85	2.81	2.20	6.32
	mm	80	118	47	242	90	114	155	63	161	149	71	56	161
8	in	4.13	4.65	1.86	12.03	3.55	5.86	7.80	2.48	7.44	7.23	3.89	2.20	7.95
	mm	105	118	47	306	90	149	198	63	189	184	99	56	202
9	in	2.69	3.15	-	9.12	2.11	4.28	5.30	-	4.51	5.47	2.40	2.06	5.39
	mm	68	80	-	232	53	109	135	-	144	139	61	52	137
10	in	3.16	3.15	-	9.54	2.11	4.66	6.09	-	4.92	5.85	2.81	2.06	6.32
	mm	80	80	-	242	53	118	155	-	125	149	71	52	161

Const. Ref. 6-8

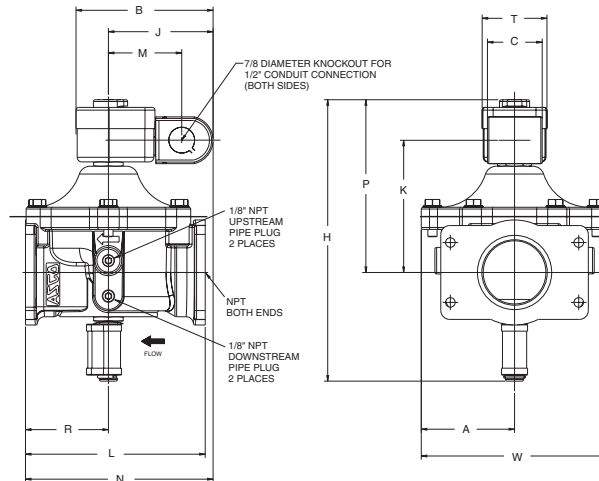

Const. Ref. 9, 10

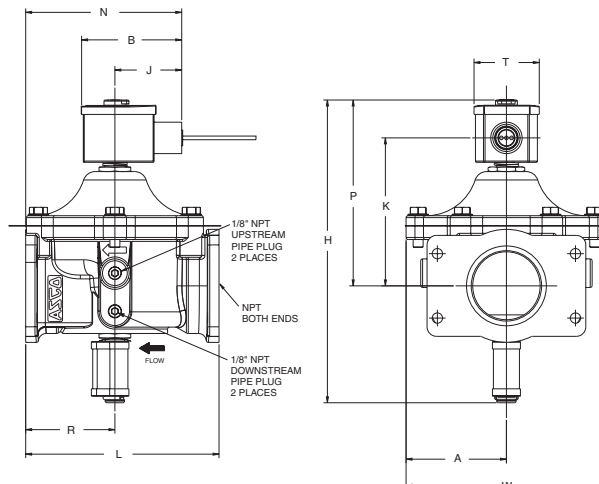

Visual Indication constructions (Suffix VI) must be mounted with solenoid vertical and upright.

Dimensions inches (mm)

Const. Ref.		A	B	C	F	G	H	J	K	L	M	N	P	R	T	U	W	Y
11	in	2.69	4.64	1.86	2.91	2.60	10.99	3.55	4.14	5.30	2.48	5.95	5.51	2.40	2.20	1.18	5.39	1.69
	mm	68	118	47	74	66	279	90	105	135	63	151	140	61	56	30	137	43
12	in	3.16	4.64	1.86	2.91	2.60	11.36	3.55	4.48	6.09	2.48	6.36	5.85	2.81	2.20	1.18	6.32	1.69
	mm	80	118	47	74	66	289	90	114	155	63	161	149	71	56	30	161	43
13	in	4.13	4.65	1.86	2.91	2.60	13.88	3.55	5.86	7.80	2.48	7.44	7.23	3.89	2.20	1.18	7.95	1.69
	mm	105	118	47	74	66	352	90	149	198	63	189	184	99	56	30	202	43
14	in	2.69	3.15	-	2.91	2.58	10.95	2.11	4.28	5.30	-	4.51	5.47	2.40	2.06	1.18	5.39	1.69
	mm	68	80	-	74	66	278	53	109	135	-	114	139	61	52	30	137	43
15	in	3.16	3.17	-	2.91	2.58	11.36	2.1	4.66	6.09	-	4.92	5.85	2.81	2.06	1.18	6.32	1.69
	mm	80	80	-	74	66	289	53	118	155	-	125	149	71	52	30	161	43

Const. Ref. 11-13

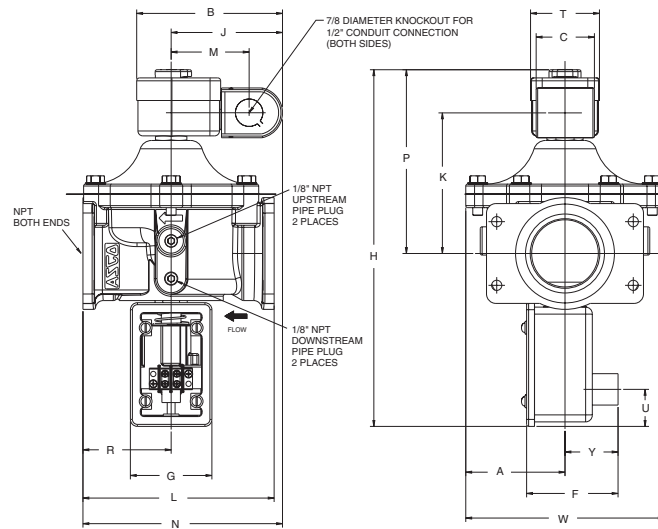

Const. Ref. 14, 15

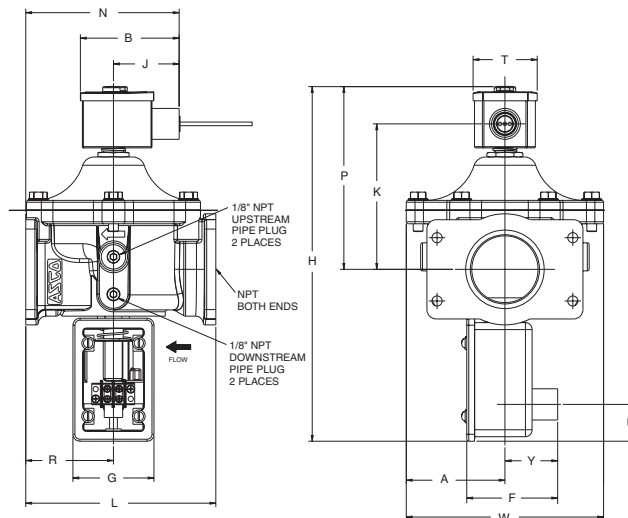

Proof of Closure constructions (Suffix C) must be mounted with solenoid vertical and upright.

Dimensions inches (mm)

Flange Adapters		B1	H1	L1	HEX
3/4" - 1"	in	4.8	2.5	1.27	2.5
	mm	122	76	32	64
1 1/4" - 2"	in	5	3.56	1.38	3
	mm	127	90	35	76
2" (High Flow) - 3"	in	7	4.5	2.015	4.5
	mm	178	114	51	114

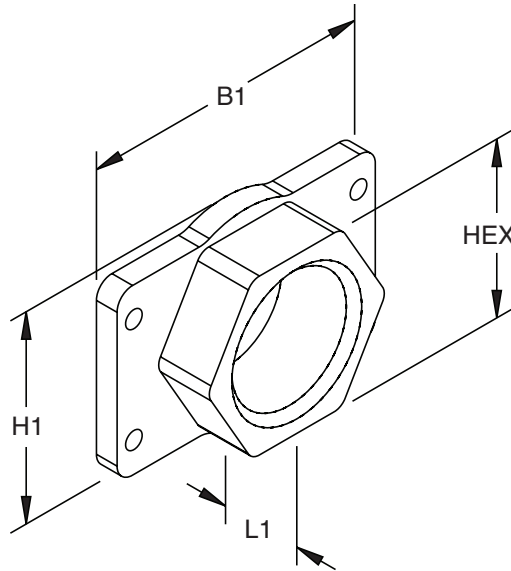

Flange Adapter Kits (Optional)*

Pipe Size (in)	Inlet & Outlet Adapter/Hardware Kit	Approx. Shipping Weight (lbs)
3/4	296659-001	1.6
1	296659-002	1.5
1 1/4	296659-003	1.3
1 1/2	296659-004	1.2
1 1/4 (High Flow)	296659-005	2.4
1 1/2 (High Flow)	296659-006	2.1
2	296659-007	1.7
2 (High Flow)	296659-008	6.6
2 1/2	296659-009	6.0
3	296659-010	4.9

* Please refer to the Double Gas Shutoff Valves catalog pages for more kit information.

General Purpose Rebuild Kits

Pipe Size (in)	Standard Rebuild Kit		
	Suffix	AC	DC
3/4, 1 1/4, 1 1/2, 2	None	323632	323946
	VI	323637	-
1 1/4 (High Flow), 1 1/2 (High Flow), 2	None	323499	323522
	VI	323501	-
2 (High Flow), 2 1/2, 3	None	323947	-
	VI	323948	-

Watertight Rebuild Kits

Pipe Size (in)	Standard Rebuild Kit		
	Suffix	AC	DC
3/4, 1 1/4, 1 1/2, 2	None	323939	-
	VI	323941	-
1 1/4, 1 1/2, 2	None	323538	-
	VI	323539	-